

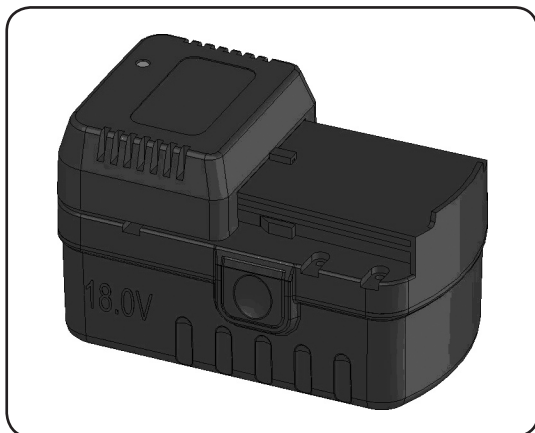

3–5 HOUR, 18 VOLT, BATTERY PACK CHARGER

Model 67031

SET UP AND OPERATING INSTRUCTIONS



NOTE: BATTERY PACK (67029) SOLD SEPARATELY.

Distributed exclusively by Harbor Freight Tools®.

3491 Mission Oaks Blvd., Camarillo, CA 93011

Visit our website at: <http://www.harborfreight.com>



**Read this material before using this product.
Failure to do so can result in serious injury.
SAVE THIS MANUAL.**

Copyright© 2009 by Harbor Freight Tools®. All rights reserved. No portion of this manual or any artwork contained herein may be reproduced in any shape or form without the express written consent of Harbor Freight Tools. Diagrams within this manual may not be drawn proportionally. Due to continuing improvements, actual product may differ slightly from the product described herein. Tools required for assembly and service may not be included.

For technical questions or replacement parts, please call 1-800-444-3353.

SAVE THIS MANUAL

Keep this manual for the safety warnings and precautions, assembly, operating, inspection, maintenance and cleaning procedures. Write the product's serial number in the back of the manual near the parts list (or month and year of purchase if product has no number). Keep this manual and the receipt in a safe and dry place for future reference.

IMPORTANT SAFETY INFORMATION

In this manual, on the labeling, and all other information provided with this product:



This is the safety alert symbol. It is used to alert you to potential personal injury hazards. Obey all safety messages that follow this symbol to avoid possible injury or death.



DANGER indicates a hazardous situation which, if not avoided, will result in death or serious injury.



WARNING indicates a hazardous situation which, if not avoided, could result in death or serious injury.

CAUTION

CAUTION, used with the safety alert symbol, indicates a hazardous situation which, if not avoided, could result in minor or moderate injury.

NOTICE

NOTICE is used to address practices not related to personal injury.

CAUTION

CAUTION, without the safety alert symbol, is used to address practices not related to personal injury.

General Safety Rules



WARNING Read all safety warnings and instructions. *Failure to follow the warnings and instructions may result in electric shock, fire and/or serious injury.* Save all warnings and instructions for future reference.

The warnings, precautions, and instructions discussed in this instruction manual cannot cover all possible conditions and situations that may occur. It must be understood by the operator that common sense and caution are factors which cannot be built into this product, but must be supplied by the operator.

1.



Use on dry, flat, fireproof surface only. The Charger gets hot during use. The Charger's heat can build up to unsafe levels and create a fire hazard if it does not receive adequate ventilation, due to an electrical fault, or if it is used in a hot environment. Do not place the Charger on a flammable surface. Do not obstruct any vents on the Charger. **Especially avoid placing the Charger on carpets and rugs; they are not only flammable, but they also obstruct vents under the Charger.**

Place the Charger on a stable, solid, nonflammable surface (such as a stable metal workbench or concrete floor) at least 1 foot away from all flammable objects, such as drapes or walls. Keep a fire extinguisher and a smoke detector in the area. Frequently monitor the Charger and battery pack during use.

2. **Charge only designated battery packs; others may overheat, leak, or burst.**
3. **Follow charging instructions.**
4. **Do not insert damaged battery pack.**
5. **Check frequently while charging.**
6. **Wear ANSI-approved safety goggles during use.**
7. **Use chargers only with specifically designated battery packs.** *Use of any other battery packs may create a risk of injury and fire.*

8. **When battery pack is not in use, keep it away from other metal objects, like paper clips, coins, keys, nails, screws or other small metal objects, that can make a connection from one terminal to another.** *Shorting the battery pack terminals together may cause burns or a fire.*

9. **Under abusive conditions, liquid may be ejected from the battery pack; avoid contact. If contact accidentally occurs, flush with water. If liquid contacts eyes, additionally seek medical help.** *Liquid ejected from the battery pack may cause irritation or burns.*

10. Do not expose chargers to rain or wet conditions. Water entering a Charger will increase the risk of electric shock. Charge indoors only.
11. Keep charging area clean and well lit. Cluttered or dark areas invite accidents.
12. Do not operate chargers in explosive atmospheres, such as in the presence of flammable liquids, gases or dust. Chargers create sparks which may ignite the dust or fumes.
13. Charger plugs must match the outlet. Never modify the plug in any way. Unmodified plugs and matching outlets will reduce risk of electric shock.
14. Do not abuse the cord. Never use the cord for carrying, pulling or unplugging the Charger. Keep cord away from heat, oil, sharp edges or moving parts. Damaged or entangled cords increase the risk of electric shock.

15. Store idle chargers out of the reach of children and do not allow persons unfamiliar with the Charger or these instructions to operate the Charger.
16. Maintain chargers. Check for breakage of parts and any other condition that may affect the Charger's operation. If damaged, have the Charger repaired before use.
17. Have your Charger serviced by a qualified repair person using only identical replacement parts. This will ensure that the safety of the Charger is maintained.
18. Inspect before every use; do not use if parts are loose or damaged.
19. Use as intended only.
20. Unplug after use and before service, cleaning or storage.
21. Maintain labels and nameplates on the Charger. These carry important safety information. If unreadable or missing, contact Harbor Freight Tools for a replacement.
22. This product is not a toy. Keep it out of reach of children.
23. People with pacemakers should consult their physician(s) before use. Electromagnetic fields in close proximity to heart pacemaker could cause pacemaker interference or pacemaker failure. In addition, people with pacemakers should properly maintain and inspect to avoid electrical shock.
24. **WARNING:** Handling the cord on this product will expose you to lead, a chemical known to the State of California to cause cancer, and birth defects or other reproductive harm. Wash hands after handling. (California Health & Safety Code § 25249.5, *et seq.*)



**SAVE THESE
INSTRUCTIONS.**

GROUNDING

⚠ WARNING

Improperly connecting the

grounding wire can result in electric shock.

Check with a qualified electrician if you are in doubt as to whether the outlet is properly grounded. Do not modify the power cord plug provided with the Charger. Do not use the Charger if the power cord or plug is damaged. If damaged, have it repaired by a service facility before use. If the plug will not fit the outlet, have a proper outlet installed by a qualified electrician.







shown in the preceding illustration.
(See Outlets for 2-Prong Plug.)

Extension Cords

Note: Extension cords must not be used with this Charger.

Symbology

	Double Insulated
	Canadian Standards Association
	Underwriters Laboratories, Inc.
	Volts Alternating Current
	Amperes

Double Insulated Chargers: Chargers with Two Prong Plugs

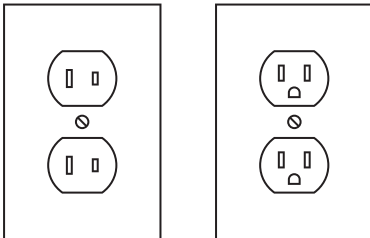

Outlets for 2-Prong Plug

1. Chargers marked "Double Insulated" do not require grounding. They have a special double insulation system which satisfies OSHA requirements and complies with the applicable standards of Underwriters Laboratories, Inc., the Canadian Standard Association, and the National Electrical Code.
(See Outlets for 2-Prong Plug.)
2. Double insulated chargers may be used in either of the 120 volt outlets

SPECIFICATIONS

Electrical Input	120 V~ / 60 Hz
Electrical Output	22 VDC / 500 mA
Charge Time	3-5 hours
Charging Capability	67029 - 18 V, 1.3 A, NiCd Battery Pack (sold separately)

UNPACKING

When unpacking, make sure that the item is intact and undamaged. If any parts are missing or broken, please call Harbor Freight Tools at 1-800-444-3353 as soon as possible.

OPERATING INSTRUCTIONS



Read the **ENTIRE IMPORTANT SAFETY INFORMATION** section at the beginning of this manual including all text under subheadings therein before set up or use of this product.

1. Place the Battery Pack on a dry fireproof surface in a room where the temperature is from 50–104° F.
2. Allow the Battery Pack to cool completely before charging. **Make sure the battery pack is undamaged; do not charge a cracked or leaking battery pack.**
3. Disconnect the Cord from the Charger. Attach the plug to a grounded, 120 V~, 60 Hz outlet.

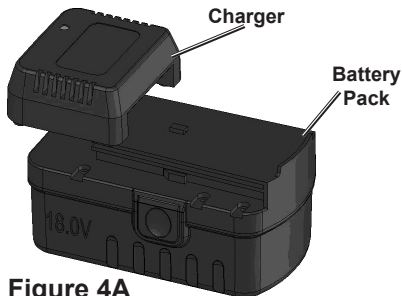

Figure 4A

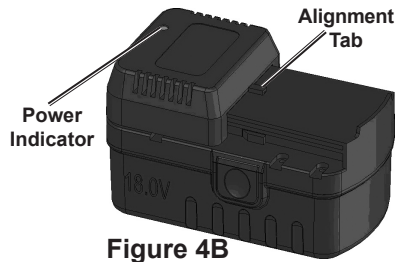

Figure 4B

4. Slide the Charger onto the Battery Pack until it firmly rests in place against the alignment tab (see Figures 4A and 4B). If the Charger does not fit properly, disconnect it and confirm that the Battery Pack is the correct model for this Charger as shown on the *Specification* chart. **Do not charge any Battery Pack not listed or any Battery Pack that the Charger does not securely fit.**
5. Attach the Cord to the Charger. The Power Indicator will light to show that the power is connected.
6. For a fully discharged battery or a new battery, allow the Battery Pack to Charge for at least 3 hours. **Do not charge the Battery Pack longer than 5 hours.**

WARNING! TIME the charging cycle.
The battery charger will not signal when charging is finished.

7. Unplug the Charger and disconnect it from the Battery Pack when finished.
8. Allow the Battery Pack to cool completely before using it.
9. Store the Charger and Battery Pack indoors, out of reach of children.

USER-MAINTENANCE INSTRUCTIONS



Procedures not specifically explained in this manual must be performed only by a qualified technician.

WARNING TO PREVENT SERIOUS INJURY

FROM ACCIDENTAL OPERATION:

Unplug the Charger before performing any inspection, maintenance, or cleaning procedures.

TO PREVENT SERIOUS INJURY FROM CHARGER OR BATTERY PACK FAILURE:

Do not use damaged charger/ battery pack.

1. **BEFORE EACH USE**, inspect the general condition of the Charger. Check for loose hardware, cracked or broken parts, damaged electrical wiring, and any other condition that may affect its safe operation.
2. **AFTER USE**, wipe external surfaces of the Charger with clean, cloth.
3. **Ni-Cd BATTERY MUST BE RECYCLED OR DISPOSED OF PROPERLY. Do not short, incinerate or open Battery Pack.**

PLEASE READ THE FOLLOWING CAREFULLY

THE MANUFACTURER AND/OR DISTRIBUTOR HAS PROVIDED THE PARTS LIST IN THIS MANUAL AS A REFERENCE TOOL ONLY. NEITHER THE MANUFACTURER OR DISTRIBUTOR MAKES ANY REPRESENTATION OR WARRANTY OF ANY KIND TO THE BUYER THAT HE OR SHE IS QUALIFIED TO MAKE ANY REPAIRS TO THE PRODUCT, OR THAT HE OR SHE IS QUALIFIED TO REPLACE ANY PARTS OF THE PRODUCT. IN FACT, THE MANUFACTURER AND/OR DISTRIBUTOR EXPRESSLY STATES THAT ALL REPAIRS AND PARTS REPLACEMENTS SHOULD BE UNDERTAKEN BY CERTIFIED AND LICENSED TECHNICIANS, AND NOT BY THE BUYER. THE BUYER ASSUMES ALL RISK AND LIABILITY ARISING OUT OF HIS OR HER REPAIRS TO THE ORIGINAL PRODUCT OR REPLACEMENT PARTS THERETO, OR ARISING OUT OF HIS OR HER INSTALLATION OF REPLACEMENT PARTS THERETO.

PARTS LIST

Part	Description
1	Charger
2	AC/DC Adapter

Record Product's Serial Number Here:

Note: If product has no serial number, record month and year of purchase instead.

Note: Some parts are listed for illustration purposes only, and are not available individually as replacement parts.

LIMITED 90 DAY WARRANTY

Harbor Freight Tools Co. makes every effort to assure that its products meet high quality and durability standards, and warrants to the original purchaser that this product is free from defects in materials and workmanship for the period of 90 days from the date of purchase. This warranty does not apply to damage due directly or indirectly, to misuse, abuse, negligence or accidents, repairs or alterations outside our facilities, criminal activity, improper installation, normal wear and tear, or to lack of maintenance. We shall in no event be liable for death, injuries to persons or property, or for incidental, contingent, special or consequential damages arising from the use of our product. Some states do not allow the exclusion or limitation of incidental or consequential damages, so the above limitation of exclusion may not apply to you. THIS WARRANTY IS EXPRESSLY IN LIEU OF ALL OTHER WARRANTIES, EXPRESS OR IMPLIED, INCLUDING THE WARRANTIES OF MERCHANTABILITY AND FITNESS.

To take advantage of this warranty, the product or part must be returned to us with transportation charges prepaid. Proof of purchase date and an explanation of the complaint must accompany the merchandise. If our inspection verifies the defect, we will either repair or replace the product at our election or we may elect to refund the purchase price if we cannot readily and quickly provide you with a replacement. We will return repaired products at our expense, but if we determine there is no defect, or that the defect resulted from causes not within the scope of our warranty, then you must bear the cost of returning the product.

This warranty gives you specific legal rights and you may also have other rights which vary from state to state.

**3491 Mission Oaks Blvd. • PO Box
6009 • Camarillo, CA 93011 • (800)
444-3353**